

Technical data sheet

Product features



Pasta cooker electric automatic water loading

Model	SAP Code	00013573
--------------	-----------------	----------



- Basin volume [l]: 40
- Water inlet: automatic valve operated by button
- Drain type: Through the substructure with connection to waste
- Drain: Yes
- Material: Stainless steel
- Protection of controls: IPX5
- Maximum device temperature [°C]: 110
- Number of baskets: 0

SAP Code	00013573	Loading	400 V / 3N - 50 Hz
Net Width [mm]	400	Basin volume [l]	40
Net Depth [mm]	800	Number of baskets	0
Net Height [mm]	510	Number of GN / EN	1
Net Weight [kg]	25.00	GN / EN size in device	GN 1/1
Power electric [kW]	13.500		

Technical data sheet

Technical drawing



Pasta cooker electric automatic water loading

Model

SAP Code

00013573

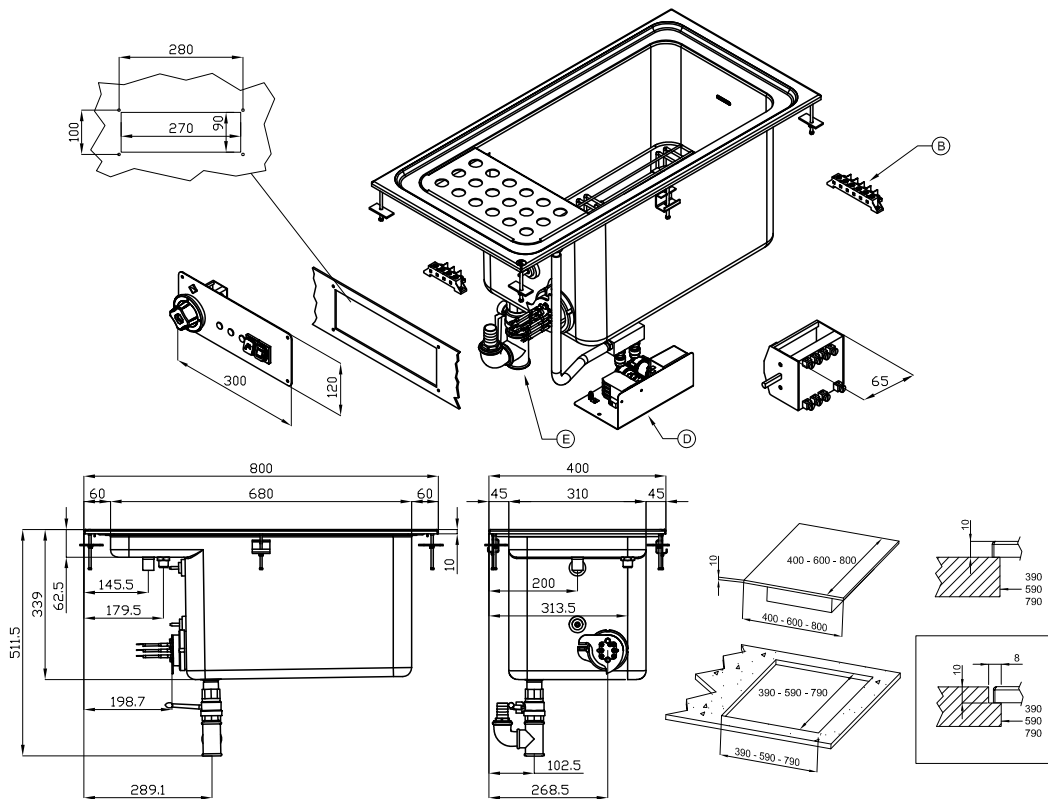

A	Data plate		B	Electrical connection	
D	Cold water connection	ISO 7-1 1/2" F	E	Water drainage	ISO 7-1 1" F

Technical data sheet

Technical parameters



Pasta cooker electric automatic water loading

Model

SAP Code

00013573

1. SAP Code:

00013573

2. Net Width [mm]:

400

3. Net Depth [mm]:

800

4. Net Height [mm]:

510

5. Net Weight [kg]:

25.00

6. Gross Width [mm]:

430

7. Gross depth [mm]:

970

8. Gross Height [mm]:

630

9. Gross Weight [kg]:

30.00

10. Device type:

Electric unit

11. Construction type of device:

Drop-in

12. Power electric [kW]:

13.500

13. Loading:

400 V / 3N - 50 Hz

14. Protection of controls:

IPX5

15. Material:

Stainless steel

16. Indicators:

operation and warm-up

17. Drain valve diameter:

1"

18. Worktop type:

Molded - comfortable cleaning maintenance

19. Basin volume [l]:

40

20. Basin dimensions [mm x mm x mm]:

307 x 509 x 327

21. Maximum device temperature [°C]:

110

22. Minimum device temperature [°C]:

30

23. Power control type:

knob control

24. Service accessibility:

Trough the frontal panel

25. Safety element:

safety thermostat
microswitch preventing the device from running when there is no water in the bath
overflow channel

26. Safety thermostat:

Yes

Technical data sheet

Technical parameters



Pasta cooker electric automatic water loading

Model

SAP Code

00013573

27. Additional information:

basket not included - baskets in different sizes can be purchased

28. Number of baskets:

0

29. Number of basins:

1

30. Basin material:

AISI 316 - Stainless steel highly resistant to salt water

31. Heating element construction:

Swivel

32. Water inlet:

automatic valve operated by button

33. Drain type:

Through the substructure with connection to waste

34. Drain:

Yes

35. Number of GN / EN:

1

36. GN / EN size in device:

GN 1/1

37. Drain connection:

Yes

38. Heating location:

Inside the tank